

Motor M42 with worm gear SN17

- Aluminium gearhousing, hardened steel worm wheel, permanent grease lubrication, output with ball bearing, optional second shaft or output shaft left
- Other reductions, output shaft or connection cable on request

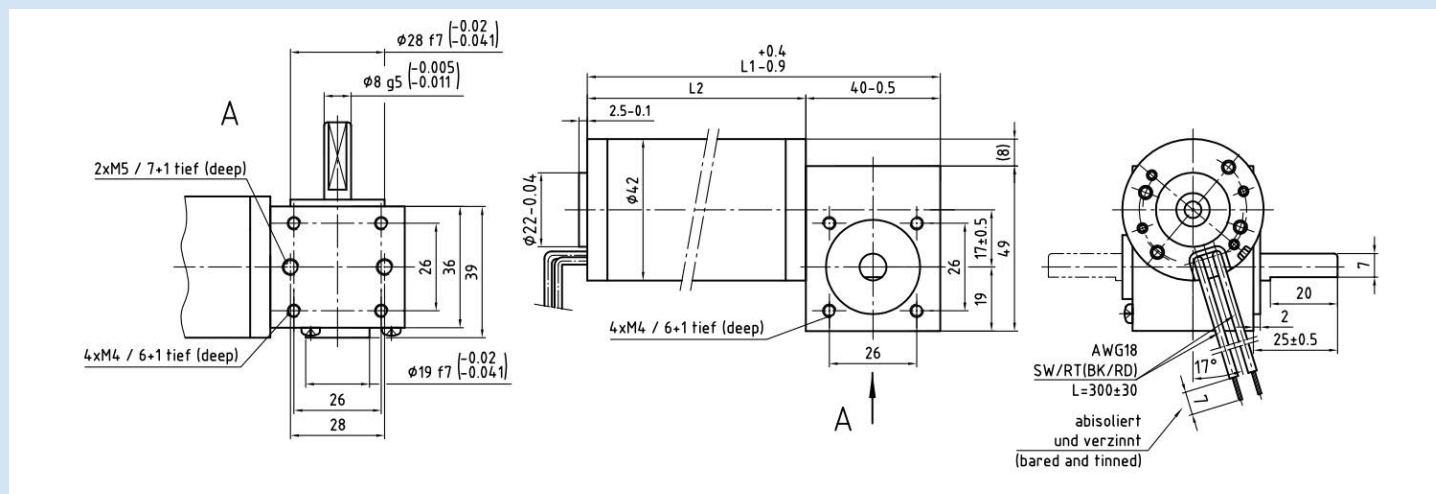

Gear reduction table M42xXX/I+ SN17

Application on request

Gear reduction	Efficiency of the gear	Speed at motor-speed 3000rpm	Nominal torque in S1-operation				
			M42x15/I L2 = 70 mm	M42x20/I L2 = 75 mm	M42x30/I L2 = 85 mm	M42x40/I L2 = 95 mm	
[i = x:1]	[%]	[1/min]	[Ncm]	[Ncm]	[Ncm]	[Ncm] 12V	[Ncm] 24V
10	69	300	27.6	34.5	44.85	55.2	62.1
15	61	200	36.6	45.75	59.48	73.2	82.35
25	48	120	48	60	78	96	108
40	34	75	54.4	68	88.4	108.8	122.4
50	38	60	76	96	123.5	152	171
75	25	40	75	93.75	121.88	150	168.75

Gear reduction	Efficiency of the gear	Speed at motor-speed 3000rpm	Nominal torque in S3-operation				
			M42x15/I L2 = 70 mm	M42x20/I L2 = 75 mm	M42x30/I L2 = 85 mm	M42x40/I L2 = 95 mm	
[i = x:1]	[%]	[1/min]	[Ncm]	[Ncm]	[Ncm]	[Ncm] 12V	[Ncm] 24V
10	74	300	44.4	55.5	72.15	88.8	99.9
15	68	200	61.2	76.5	99.45	122.4	137.7
25	56	120	84	105	136.5	168	189
40	39	75	93.6	117	152.1	187.2	210.6
50	42	60	126	157.5	204.75	252	283.5
75	28	40	126	157.5	204.75	252	283.5

General gear data

Material worm wheel		Brass
Maximum torque	[Ncm]	300
Permissible shaft load	[N] (axial / radial)	80 / 200
Gear length	[mm]	40

Stand: 24. Juli 2020 – changes reserved